

SERPAC 031-1

Electronics Enclosures

NOTES:
1. WHEN MACHINE OR 1 PLATES MODIFICATIONS ARE REQUIRED,
USE THE CENTER OF THE BOX TO DIMENSION.

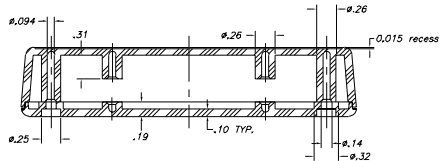
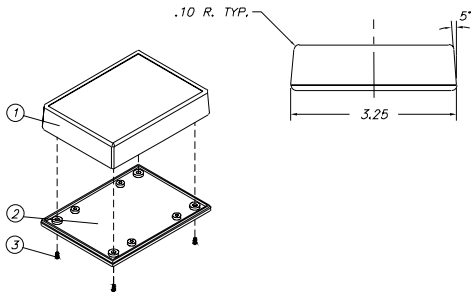
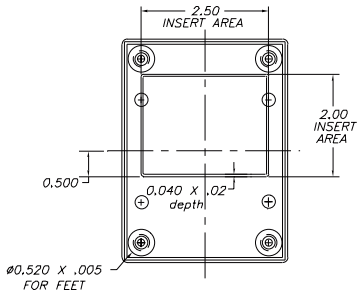
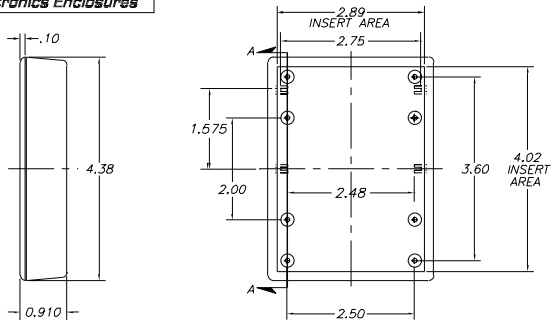

SECTION A-A

8-17-98.

ALL DIMENSIONS ± .010

ITEM	PART NO.	DESCRIPTION	ACCESSORIES	
1	311	PLASTIC TOP	PART NO.	DESCRIPTION
2	03	PLASTIC BOTTOM	51	FEET
3	6005	SCREWS (4)	330	PROTOTYPE GRID BOARD (HORIZ.)
			430	PROTOTYPE CLAD BOARD (HORIZ.)

619 Commercial Ave. Covina, CA 91723

(626) 331-0517 Fax (626) 331-8564 <http://www.serpac.com>